

## MOTORIZED VALVES TECHNICAL CHARACTERISTICS AND PERFORMANCES

TECHNICAL DATA	3FGB DN 25÷150	2FSA DN 25÷80	3FSAS DN 25÷80	3FAA DN 25÷125	3FAAP DN 25÷125
Construction	PN16	PN25	PN25 <sup>(3)</sup>	PN40 <sup>(7)</sup>	PN40 <sup>(7)</sup>
Body	cast iron	spheroidal cast iron	spheroidal cast iron	acciaio	acciaio
Seat	cast iron	stainless steel	stainless steel	stainless steel	stainless steel
Plug	forged brass	stainless steel	stainless steel	stainless steel	stainless steel
Stem (D 9mm)	stainless steel	stainless steel	stainless steel	stainless steel	stainless steel
Control characteristic	direct way = equal perc. Angle way = linear	direct way = equal perc. (DN25÷65) linear (DN80) angle way = linear	direct way = equal perc. (DN25÷65) linear (DN80) angle way = linear	linear	linear
Stem packing	EPDM O-Ring <sup>(5)</sup>	Teflon V-ring	stainless steel bellows	Teflon V-ring	(2)
Max. fluid temp. °C	150	230	300	230	350
Min. fluid temp. °C	-10 <sup>(1)</sup>	-10 <sup>(1)</sup>	-10 <sup>(1)</sup>	-10 <sup>(1)</sup>	-20 <sup>(1)</sup> (4)
Fluid <sup>(6)</sup>	Group 2	Group 2	Group 1	Group 2 and 1	Group 1
Connections	Flanged PN16	Flanged PN25	Flanged PN25	Flanged PN40	Flanged PN40
max Kvs leakage % <sup>(8)</sup>	direct way 0,03 angle way 2	0,02	0,02	0,02	0,02

- (1) For applications with possible ice formation on stem and gasket, see 248 accessory.  
 (2) Graphite packing for high temperatures; forced lubrication on extended neck. Teflon packing for low temperatures, see (4).  
 (3) Due to the bellows presence, the max applicable pressure must not be higher than 5bar.  
 (4) For applications on fluids from -10 to -20°C replace letter P with the T, e.g. 3FAA50T. In such case the max temperature is 230°C

- (5) Double O-ring and graphite teflon scraper ring.  
 (6) Group 1: water, overheated water, steam, diathermic oil.  
 For different fluids belonging to group 1, please contact our Sales Support.  
 Group 2: water, overheated water, glycole added water (50% max.) steam.  
 For different fluids belonging to group 2, please contact our Sales Support.  
 (7) PN25 only for 3FAA125 and 3FAA125P.  
 (8) Leakage is measured according to the EN1349 standard.

### USE

3F.. series valves are used to control fluids belonging to the group showed in the table in accordance to article 9 of 97/23/CE (PED) directive, in air-conditioning, thermoventilation and heating plants and in industrial processes; therefore, they cannot be used as safety valves.

### MANUFACTURING CHARACTERISTICS

They consist in a 3-way valve body to be assembled on electrical bidirectional actuator.

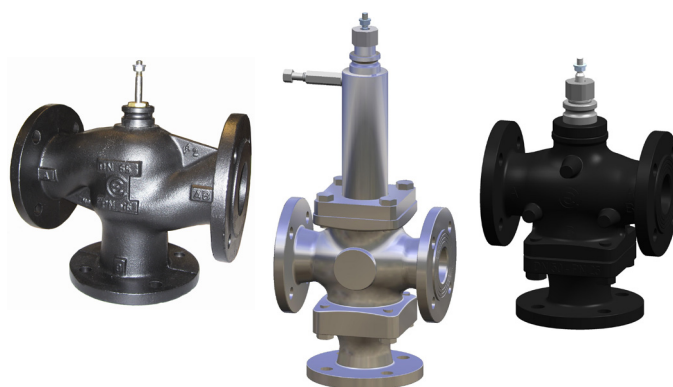

## INSTALLATION

### HYDRAULIC CONNECTIONS

Respect the fluid direction as indicated in Fig. 1 and 2. In particular, we specify that the valves must be mounted as mixing valves with inlet in A and in B and outlet AB.

### VALVE MOUNTING

Before mounting the valve, make sure pipes are clean, free from welding slags. The pipes must be perfectly aligned with the valve body and not subjected to vibrations. For installations on plants with high temperature fluids (steam, overheated water, diathermic oil) use expansion joints to avoid the dilatation of pipes to stress the valve body.

Install the valves with the actuator in vertical position for fluid temperature up to 120°C, with higher temperatures they must be mounted horizontally.

**NOTE:** Following the hydraulic installation it is necessary to check the tight of the stem packing placed on the bonnet, both in cases of low and high temperatures. The valves require periodic maintenance.

Avoid the valve installation in plants, which are considered aggressive and/or corrosive for valve materials.

Please contact our Sales Support in order to determine which potentially aggressive or polluting substances can be used.

We disclaim all responsibility in case of valve failure due to external fortuitous events (fire, earthquakes etc.).

**Note:** The actuator can be rotated with respect to the valve body by blocking the ring nut; after such operation re-tighten the ring nut.

**Attention:** The stem of 3FSA.S bellows seal valves must never rotate with respect to the valve body if it is connected to through the bellows.

### ACTUATORS TECHNICAL CHARACTERISTICS, WIRING DIAGRAMS AND INSTALLATION

See actuators data sheets and mounting instructions.

### MOTORIZED VALVES OPTIONS

MODEL	DESCRIPTION
A125-3	flanges with ANSI125 bolt holes (for 3FSA/3FSAS DN50÷65 and 3FGB DN25÷150)
A150-3	flanges with ANSI 150 bolt holes (for 3FSA/3FSAS DN50÷65 and 3FAA/3FAAP DN50÷125 valves)
A300-3	flanges with ANSI 300 bolt holes (for 3FSA/3FSAS DN25÷65, 3FAA/3FAAP DN32÷65 and DN100÷125 valves)

### ACCESSORIES

MODEL	DESCRIPTION
248	stem heater for applications on -10°C low temperature fluid with MVH, MVF and MVE actuators

### SCHEMI APPLICATIVI

#### Constant flow mixing to the user

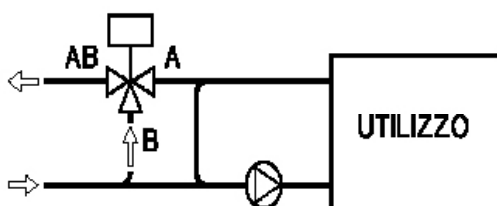

#### Variable flow mixing to the user

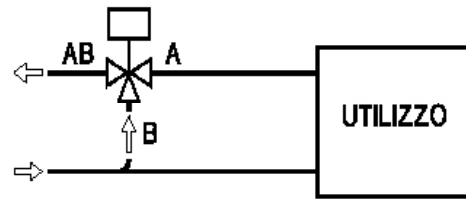

### OVERALL DIMENSIONS (mm)

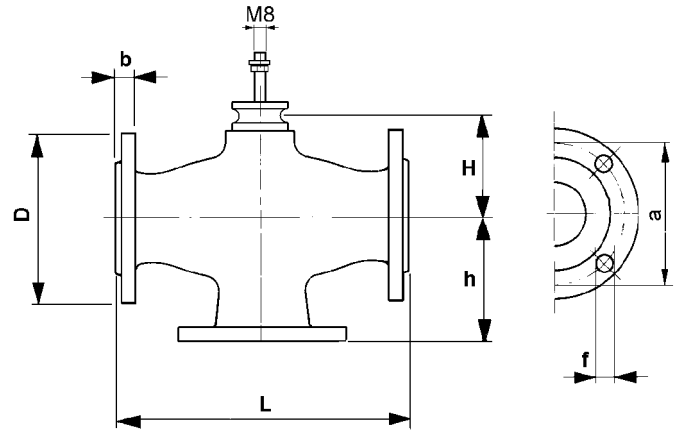

3FGB

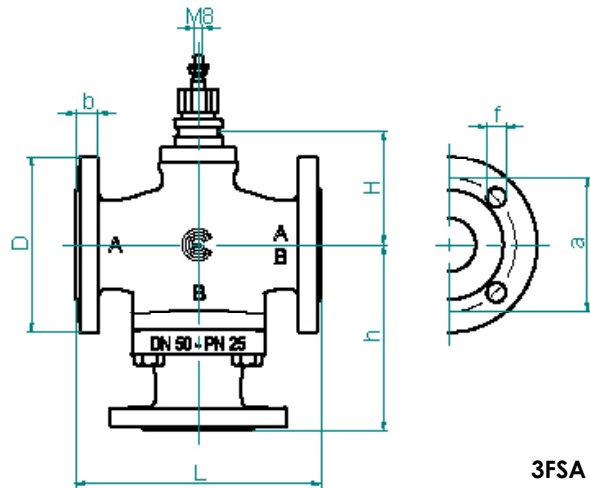

3FSA / 3FAA

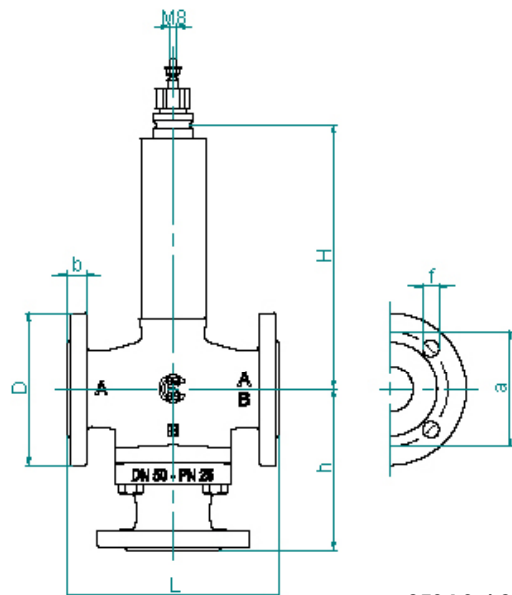

3FSAS / 3FAAP

**MAX DIFFERENTIAL AND CLOSE-OFF PRESSURE (kPa)**

U-Bolt Connection	DN	Kvs	MVH		MVHA/C*		MVH3K		MVF59A/C		MVEX06		MVEX10		MVEX15	
			A-AB	B-AB	A-AB	B-AB	A-AB	B-AB	A-AB	B-AB	A-AB	B-AB	A-AB	B-AB	A-AB	B-AB
3FGB	25R4	4	1600	1600	1100	840	1600	1600	1400	1100	940	700	1590	1270	1600	1600
	25R7	6,3	1600	1600	1100	840	1600	1600	1400	1100	940	700	1590	1270	1600	1600
	25	10	1600	1600	1100	840	1600	1600	1400	1100	940	700	1590	1270	1600	1600
	40R	19	1170	990	590	470	1600	1600	750	620	500	390	860	710	1300	1110
	40	25	1170	990	590	470	1600	1600	750	620	500	390	860	710	1300	1110
	50	40	730	630	360	300	1600	1440	470	390	310	250	530	450	810	710
	65	63	430	370	210	170	960	850	270	230	180	150	310	270	480	420
	80	100	280	240	130	110	620	560	-		110	90	200	170	310	270
	100	130	170	150	80	70	390	360			70	60	120	110	190	175
	125	200	100	100	50	40	240	230			40	40	70	70	120	110
150	300	70	70	30	30	160	160	30			20	50	50	80	75	
3FAA 3FAA...P	25R4	4	2150	1920	1080	770	3000	3000	1390	1090	930	600	1580	1300	2390	2170
	25R7	6,3	0	0	0	0	0	0	0	0	0	0	0	0		
	25	10	0	0	0	0	0	0	0	0	0	0	0			
	32	16	1450	1210	730	480	3000	2960	930	690	620	380	1060	820	1610	1370
	40	22	940	790	470	310	2090	1940	600	450	400	240	690	530	1050	900
	50	32	660	560	330	220	1470	1370	420	320	280	170	480	370	740	630
	65	70	390	330	190	130	860	810	240	180	160	100	280	220	430	370
	80	110	250	210	120	80	570	530	-		100	60	180	140	280	240
	100	140	160	140	70	50	360	340			60	40	110	90	170	150
	125	250	100	80	40	30	230	210			30	20	70	60	110	100
3FSA	25R4	4	2500	2500	2150	1250	2500	2500	2500	1850	1850	950	2500	2220	2500	2500
	25R7	6,3	2150	1690	1080	630	2500	2500	1390	930	930	470	1580	1120	2390	1930
	25	10	2150	1690	1080	630	2500	2500	1390	930	930	470	1580	1120	2390	1930
	32	19	1450	1140	730	420	2500	2500	930	620	620	310	1060	750	1610	1300
	40	25	1040	820	520	300	2310	2080	670	440	440	220	760	540	1160	940
	50	40	660	520	330	180	1470	1330	420	280	280	130	480	340	740	590
	65	63	390	300	190	100	860	780	240	160	160	70	280	190	430	340
	80	100	250	230	120	105	500	500	-		100	85	180	160	280	220
3FSA...S	25R4	4	500	500	500	500	500	500	500	500	500	500	500	500	500	500
	25R7	6,3	500	500	500	500	500	500	500	500	500	500	500	500	500	500
	25	10	500	500	500	500	500	500	500	500	500	500	500	500	500	500
	32	19	500	500	500	500	500	500	500	500	500	470	500	500	500	500
	40	25	500	500	500	420	500	500	500	500	440	340	500	500	500	500
	50	40	500	500	330	270	500	500	420	360	280	220	480	420	500	500
	65	63	390	350	190	160	500	500	240	210	160	130	280	250	430	400
	80	110	250	230	120	100	500	500	-		100	80	180	160	288	260

\* MVHA in emergency closes direct way; MVHC in emergency opens direct way.

**NOTE** In order to avoid wear between plug and seat, we recommend not to overcome the differential pressure as follows:  
 3FGB = 2bar  
 3FSA = 8bar  
 3FAA/3FAAP = 12bar

Kvs is the flow rate expressed in m<sup>3</sup>/h of water at a temperature between 5°C and 40°C passing through a valve open at the nominal stroke with 100kPa (1bar) differential pressure.

**Note** The max operating pressures at different temperatures for PN various classes must correspond to the following standards: UNI 1092-2 and UNI 12516-1.

MODEL	DN	L	H	h	D	B	A	F	HOLES NR.	WEIGHT (Kg)	STROKE (mm)
3FGB (PN 16)	25	160	50	80	115	16	85	14	4	5,2	16,5
	40	200	64	100	150	18	110	18	4	9,4	25
	50	230	66	115	165	20	125	18	4	14	25
	65	290	84	145	185	20	145	18	4	19,1	25
	80	310	94	155	200	22	160	18	8	23,5	45
	100	350	105	175	220	22	180	18	8	32	45
	125	400	128	200	250	24	210	18	8	45,6	45
	150	480	146	240	285	24	240	22	8	61,2	45
3FSA (PN 25)	25	160	92	137	115	18	85	14	4	8	16,5
	32	180	97	159	1240	20	100	18	4	12	25
	40	200	98	162	150	20	110	18	4	14	25
	50	230	107	171	165	22	125	18	4	18	25
	65	270	117	190	185	24	145	18	8	25	25
	80	310	181	207	200	26	160	18	8	42,8	45
3FAA (PN 40)	25	160	124	140	115	17	85	14	4	12,4	16,5
	32	180	139	157	140	17	100	18	4	182,2	25
	40	200	165	160	150	17	110	18	4	21,6	25
	50	230	168	172	165	19	125	18	4	26	25
	65	270	183	190	185	21	145	18	8	36	25
	80	310	199	207	200	23	160	18	8	47,8	45
	100	350	178	247	235	24	190	22	8	55	45
	125	400	203	282	270	26	220	25	8	78	45
3FSAS (PN 25)	25	160	274	137	115	18	85	14	4	10	16,5
	32	180	279	159	140	20	100	18	4	15	25
	40	200	280	162	150	20	110	18	4	17	25
	50	230	289	171	165	22	125	18	4	21	25
	65	270	299	191	185	24	145	18	8	29	25
	80	310	413	207	200	26	160	18	8	45,6	45
3FAAP (PN 40)	25	160	195	140	115	18	85	14	4	15,7	16,5
	32	180	269	157	140	18	100	18	4	22,3	25
	40	200	277	160	150	18	110	18	4	25	25
	50	230	293	172	165	20	125	18	4	29,7	25
	65	270	308	190	185	22	145	18	8	39,3	25
	80	310	324	207	200	24	160	18	8	50,8	45
	100	350	303	247	235	24	190	22	8	67	45
	125	400	328	282	270	26	220	25	8	98,6	45

The performances stated in this sheet can be modified without any prior notice due to design improvements